

DUALTRON

PERSONAL MOBILITY

User Manual



※ This product is always two-wheel drive.

Company Introduction

Minimotors Co. LTD., is a PM(Personal Mobility) specialized company who manufacture and distribute personal mobility with a professional production system since 1999 and is the representative company of personal mobility in Korea with the longest history and accumulated know-how.

Minimotors Co. LTD., launched DUALTRON(2015), the world's premium luxury electric brand has developed the most durable, safe and innovative products.

In addition, we are leading the personal mobility industry with smart management such as service reservation, product management and insurance via exclusive app, and differentiated services that provide test rides, purchases and maintenance through out 35 locations nationwide.



(주)미니모터스
www.minimotors.co.kr
Since 1999

Brand Introduction

DUALTRON™
The dream of electric technology

'DUALTRON' is a world-wide premium brand that designed and produced by Minimotres Co.LTD., ourselves.

DUALTRON' is a breakthrough product that combines the world's first dual drive system and the new rubber suspension technology (patent application). It is a proud Korean luxury brand that has won the world electric scooter market exported to more than 30 countries

Minimotors Smart Electric Insurance

From registration electric insurance to managing your own products at once!

If you are a Minimotors user, is a professional insurance app that can be fully guaranteed for all products at the same time, with only one insurance without limit.

Smart join!, Smart Insurance!

With scan the QR code, you can download the app.



Android



iOS

- Real-time service reservation function (service reservation and service feedback is possible in real time within nationwide branches)
- You can easily manage your vehicle with your own vehicle registration via My Minimotors.
- You can easily purchase Minimotors Smart Electric Insurance. (Mertz Fire)
- You can see the information of Minimotors products at a glance. (from electric kick board to other products)
- You can check the location of the branch with the Minimotors national branch information guide. (Nationwide branch office guidance and search for the nearest branch through linking with my location)
- You can easily view news events as announcements.
- User guide (safety precautions, instrument panel manual, serial number confirmation, product manual)
- Family site (Minimotors webpage, Naver cafe – Electrical vehicle riders)
- Customer Center (FAQ, Terms of Use, Privacy Policy, Location Service Terms)

✓ Please read the user manual carefully.

Do not use the product until you understand its functions.

Do not rent the product to anyone who can't operate the product.

*For the first time, **the user should use it with a slow speed'** for safety

01. Safety guidelines and restrictions 04

02. product structure 06

03. Name of each part 07

04. Product components 08

05. How to use the product 09

06. How to use the instrument panel 12

07. Product feature guide 15

08. How to use the charger correctly 16

09. Safety precautions for Lithium-ion battery 17

10. Safety guidelines before driving 18

11. Inspection and maintenance 19

12. Important checklist 22

13. Product specification table 24

14. Essential information for buyer 25

15. Product warranty 26

16. Nationwide service center 27

Before Reading Manual

This manual contains important information to help you to use your product more safely. For safe use, it is marked as ‘Danger’, ‘Caution’ and ‘Warning’ depending on the degree of danger and the meaning is as below.



Danger: Indicates a hazardous situation that could be a result of serious injury.



Warning: Indicates a potentially hazardous situation that could be a result in light injury.



Caution: Indicates a potentially hazardous situation that could be a result in serious injury.



✓ Please read this manual carefully before using this product

1 General safety guideline

✗ Even if the it is within the warranty period, you may be liable for any accident caused by any of the following causes.



1. Be careful of water!

This product and components are not waterproof. Don't let the water get into the product and components.

- Never use it, if the road is wet due to the rain, snow, hailstone.
- Never wash or spread water to electric devices.



2. Beware of folding and spinning parts!

If parts of the body, as a finger or hair, or clothe, bag, or shoe laces get caught in the spinning or folding parts of the product, this may lead to severe injuries. Please be careful.



3. No acrobatics

Stunts and jumps such as jumping and dropping are prohibited as they can cause a great impact on the product and can cause of malfunction and accidents.



4. No companion boarding

This product is intended for one adult only, so children, infants, or two people are prohibited from boarding.



5. Don't tune by yourself

Do not open or tune the electric parts (battery, controller or motor system).



6. Comply with the related laws

Please comply with the Road Traffic Act and related laws and regulations according to the place of use. Unlicensed, driving after drinking, loading cargo on the scooter is prohibited. (More than bike or bicycle license is required)

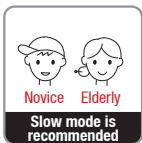

7. Beginners and seniors are encouraged to use at low speed

Beginners who are not accustomed to use the product, seniors and others should avoid high speed mode driving and recommend low speed driving. In addition, please use after practice how to ride safely in a wide place.



8. Do not sudden brake with front brake

If there is a risk of overturning, sudden deceleration should be done safely. Do not apply any unusual behaviors or artificial forces, such as stopping with your feet.



9. Do no accelerate downhill

Slow down at downhill. When reducing the speed, to prevent brake overheat, use the brakes properly to reduce the heat on the disk with proper brake use.



10. Do not drive on steep slopes

Acceptable gradeability is different for each product. Excessive hill roads exceeding the specification may cause damage to the product(part) due to temperature cut, overcurrent or low voltage cut, which may cause the product to malfunction.



11. Safety warning when lifting the product

If the product is lifted by holding only the handle, there is a possibility that the product may be damaged due to deformation of the folding part due to load or movement of the product. When lifting the product, be sure to hold the product's body (footrest) with one hand and hold the handle with the other hand so that you do not get hurt in your back or knees.



12. Be sure to wear safety equipment

For the safety of passengers, be sure to wear a full face helmet and the other protective gear(knee, elbow, hand, upper body) and do not wear shoes such as slippers, high heels that interfere with driving.

2 Precaution before driving

1. Night driving should be avoided in any case, be sure to wear helmets and other guards (knees, elbows, hands, upper body, etc.) and drive safely.
2. Select the mode that suits you and drive. In order to cope with the sudden situation, exercise to slow down to hold the brake at all times.
3. When turning left / right, slow down to avoid danger of overturning or slipping., And then slowly turn safely.
4. To go to backward, it is safe if you getting off from the product after stopping before moving.
5. It is prohibited to use in a slippery place, a crowded place, a steep slope, roads with a risk of accident, uneven road.
6. When crossing a pedestrian crossing, get off from the product for pedestrian safety.
7. Do not drive in a threat any other means of transport, such as animals, pedestrians, bicycles, motorcycles, cars, etc.
8. If you pass the speed bumps and obstacles, be sure to slow down.
9. When decelerating or braking, do not stop with using foot, but stop with using brake appropriately.
10. Be careful that there is a risk of burns due to heat from motor and brake (especially disk rotor) after driving.
11. It is prohibited to drive with all the way by holding the handle with one hand.
12. Do not ride or drive when the kick stand is down.

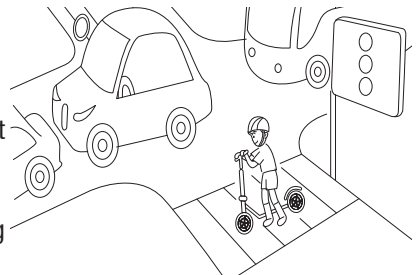

Electrical wiring diagram

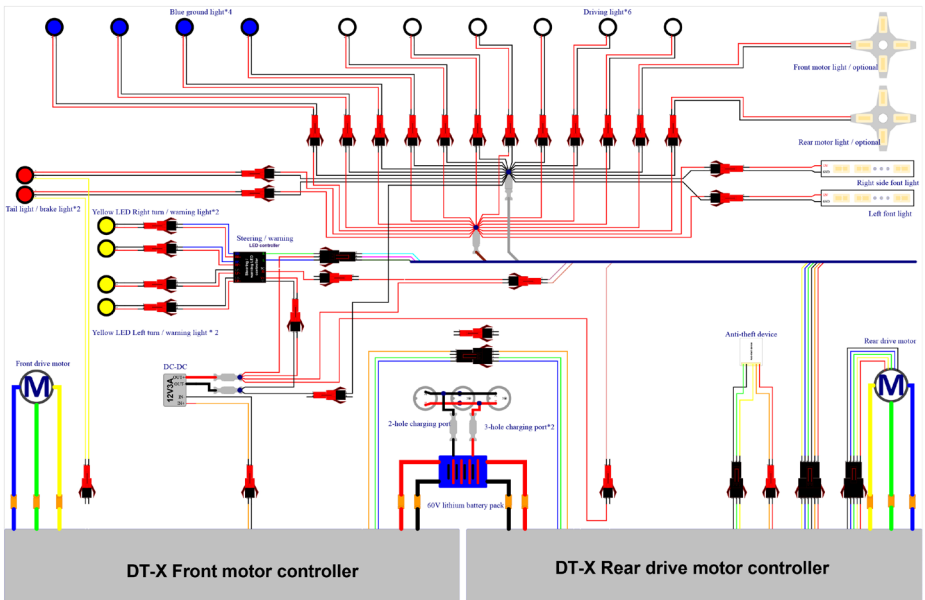

Product size

Unfolded



Folded

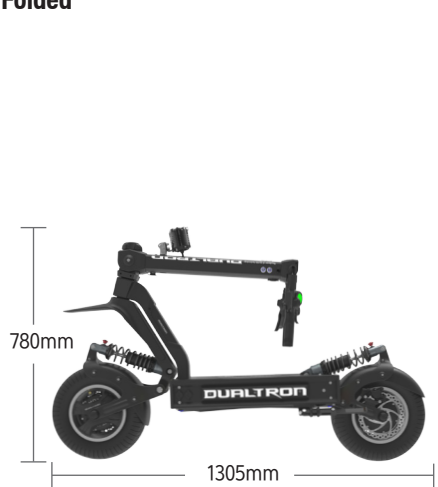

* Errors may occur depending on the measurement method.

Name of each part

DUALTRON X

Handle

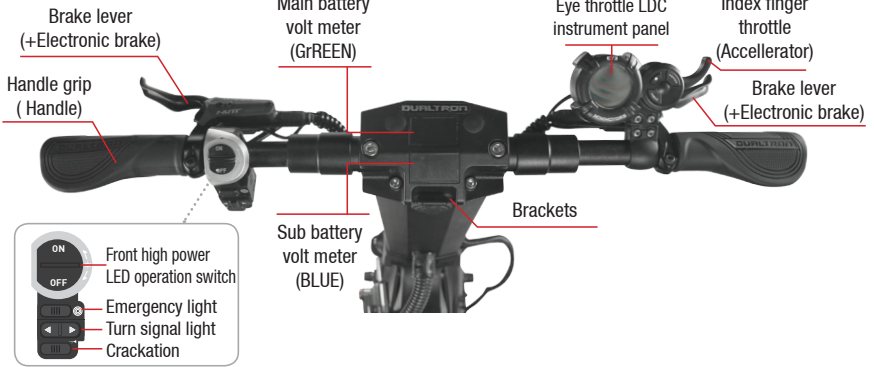

Body frame



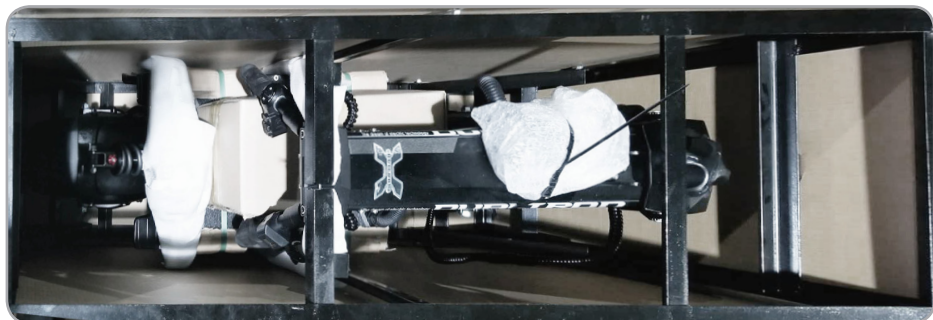

Checking the components inside of the box

Main body, Slow battery charger for 60V (1.75A) 1EA, Default tool, Swing arm fender, User manual

Ejecting the product



The chassis of this product is securely fixed on a steel frame inside the box.

When lifting the product out of the box, two or more people should open it safely considering the weight of the product.

※ Please note that there may be safety accidents such as pinching of the body part of the folding part, cutting of the cutting edge of the steel frame, or crushing due to the fall of the product.

Make a note of the serial number.



The serial number can be used to check information such as date of purchase, warranty period, etc., and product information can be checked even if the product is lost or stolen.

Assembly of instrument panel and brake



Position the instrument panel and tighten the fixing bolt.



Position the brake and tighten the fixing with 4mm hex wrench.

1 Production folding

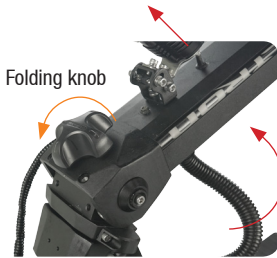

1. Raise the handle post (Steering tube)

Release the folding knob and push the handle post(steering tube) to the end.



2. Locking the folding parts

Lock the folding knob to hold it firmly and check for the looseness during use.

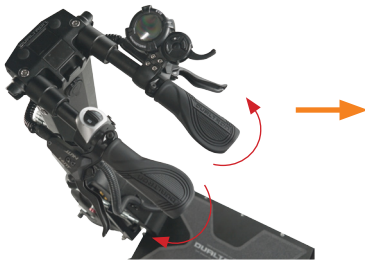

3. Handlebar unfolding

Slide both handlebars all the way out.

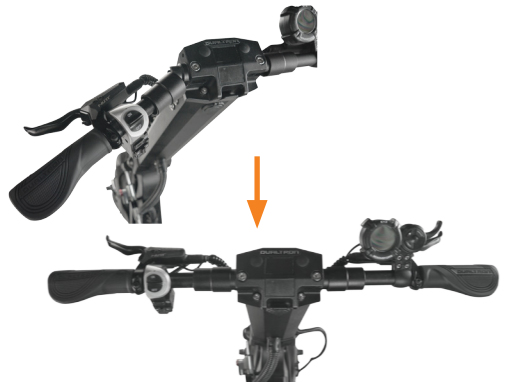

4. Adjustable side stand

According to the height of the product, the length of side stand can be adjusted. Loosen the length adjustment screw on the side stand and remove it to the left or right side. Adjust the length based on the height of the product and fix the adjustment screw firmly.



For safe mounting of the product, side stand check and length adjustment are required.

※ Be careful not to loosen or break the anti-twist screw located on the top of the side stand.

2 How to start

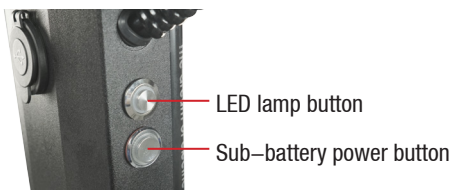

Step1. Turning on the main switch

When you turn on the product, press the POWER button on the LCD instrument panel for 2 seconds. You can start driving by setting such as departure mode, cruise mode, electronic brake and ABS functions. When you finished, turn off the LCD instrument panel and light power.

* The power of instrument panel will be turn off automatically if you don't use that for a while.

Step2. Turn on the LED lamp

Press the sub-battery power button on the right side of the steering tube to turn on the handle power. At this time, press the upper LED lighting button to turn on the high power LED and the steering tube bar.

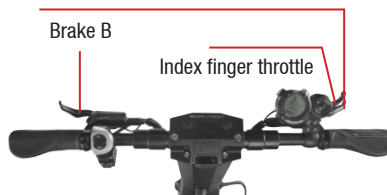
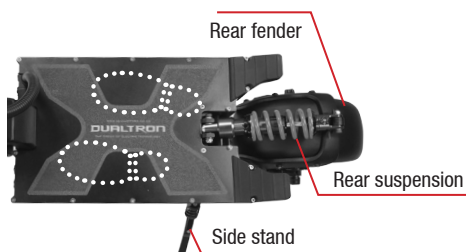

Step3. Stance for driving

After tilting the kickstand, find a stable position on the footrest and then hold the handle grip comfortably. Be careful not to raise your foot on the rear fender.

Step4. Acceleration and deceleration

Acceleration can be performed by using the index finger throttle of the instrument panel while driving, and the deceleration or stop can be performed by holding the brakes on the handle.



Caution

Before driving, be sure not to loosen the fastening part of the folding part or the handle part and the main fixing part of the product.

Make sure that the folding knob is fully locked and the folding section is firmly secured. Especially, please check the loose or damage in suspension arm fixing bolts, connecting the suspension arm and swing arm before riding to prevent safety accidents.

Regardless of whether the throttle is operated or not, the motor sensor may continue to operate, causing malfunctions such as sudden acceleration. In this case, holding the brake lever to cancel the operation. This phenomenon may be caused by corrosion of the throttling, immersion of the throttle, disconnection of the magnet, broken off levers, and breakage of the spring. Do not bounce the throttle lever strongly.

3 How to stop

Step1 Rear brake use

Be sure to use the rear brake first for decelerating when stopping while driving. For safe stop, it is necessary to practice slow down after deceleration with rear brake.

Step2 Front brake use

Rapid braking using the front wheel brake while driving may risk overturning. When stopping, use the rear wheel brake first to reduce the speed, and then use the front wheel brake together to stop safely.

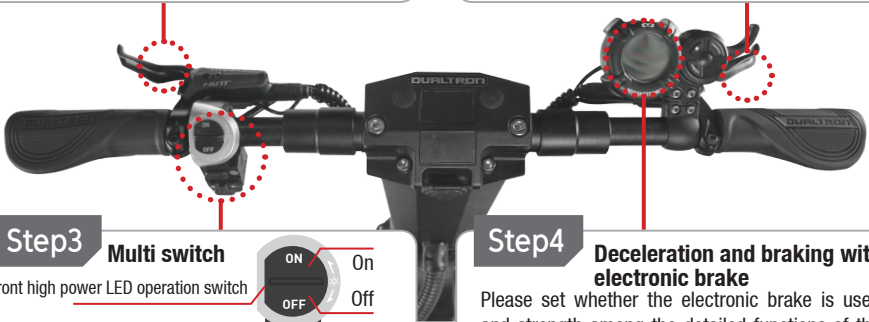

Step3 Multi switch

Front high power LED operation switch

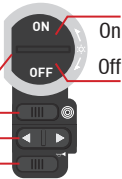

- Emergency light (Pressed—Flashing)
- Turn signal light (Left, Right flashing)
- Crackaction(Press to crack the sound)

※ Additional function High power LED will blink if you turn off and turn on the front high power LED switch within 1 second.

Step4 Deceleration and braking with electronic brake

Please set whether the electronic brake is used and strength among the detailed functions of the instrument cluster before driving.

When the brake lever is operated while driving, the electronic brake works together to increase braking force.

Tip Check for safe braking

- For safe braking, check whether the brake lever and disc caliper connection (wire damage, external breakage, etc.) are damaged before and after driving, and check brake wear and looseness of brake inner core (Inner wire). In the case of hydraulic brakes, it is also necessary to check the oil leakage or deficiency and always check that the braking force is sufficient.
- Due to various factors such as road surface condition and speed, it may not be possible to stop when brake is operated as expected. The electronic brake and ABS functions are auxiliary functions to further increase the braking force and used. The user should understand the function and expect the operation timing when use this function.

4 Product folding

Handlebar slider



1. Fold handlebar

Pull both handlebar sliders, then fold the handlebars forward.

Folding knob



2. Folding steering tube

Loosen the folding knob, press down firmly on the knob and lay the steering tube down.

How to use the instrument panel



Caution

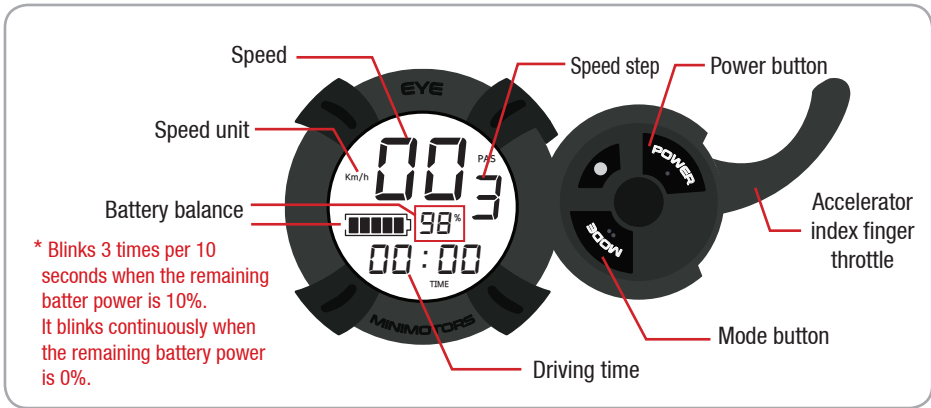

1 Speed step setting Can adjust with button.

While the instrument panel is on, press  to set the speed step. The setting is completed when the selected speed step value is selected.

2 Functions and settings for each main screen mode can adjust with button.

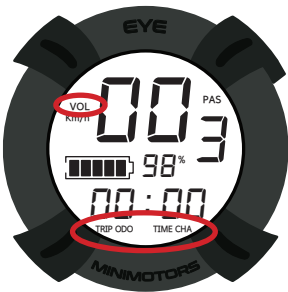

Mode	Discription
TRIP	Current mileage (Press and hold  button to reset to "0")
ODO	Accumulated mileage
CHA	Not use
VOL	Current voltage (Volt)
TIME	Driven time

3 Instrument panel detailed function

You can change the setting mode  by turning on the power of the dashboard and pressing for 2-3 seconds.

In the setting mode,  press once to change the internal setting value

* If you change the default setting values P0 (13), P1 (60), P2 (15), P3 (0), correct information will not be displayed.

Setting mode



Setting value

P0 13(Fixed)	P1 60(Fixed)	P2 15(Fixed)	P3 0(Fixed)	P4 Speed unit 0(Km/h), 1(mp/h)
P5 Start method 0(Acceleration start) 1(Kick start)	P6 Cruise mode 0(OFF) 1(ON)	P7 Safety start 5 (Fixed)	P8 Max output setting 5~100% (User adjust)	P9 Battery save 1(MAX SAVE) 2(MID SAVE) 3(NO SAVE)
PA Electronic brake power 0 (Off) ~ 5 (Powerful)	Pb Electronic brake power 0 (Off) ~ 5 (Brightest)	PC Auto off time setting 5~30 minutes	Pd ABS setting 0(OFF) 1(ON)	PE Rear motor lock setting 0(UNLOCK) 1(LOCK)

4 PE function (Rear motor lock setting)

The rear motor lock function (throttle :PD) is not activated at the factory.

■ How to active PE function (Rear motor lock setting)

- When you open the pedal of the product, the rear motor sensor (white) is located in the right space which connects the stem headset and the chassis. To activate the function, connect the disconnected connector.
- After connecting the connector, reassemble the pedal and set the throttle PE function to "1(LOCK)".



※ When the rear PE sensor is connected, the standby current is consumed even if the throw-off phase PE function is turned off. (For long term storage and uncharged, be sure to disconnect and store the connector of the rear motor sensor to prevent the discharge of the product in advance)

※ If you turn off the power after setting the PE function, the PE function works. The PE function is automatically canceled when the power is turned on again.

* To improve the quality and safety of connector and rear motor locking sensor, the part colors and specifications can be changed without notification.

5 Features of cruise mode (automatic driving)

The cruise control function allows you to maintain the driving speed automatically. Take advantage of cruise features The advantage of being able to reduce fatigue when traveling long distances and to increase mileage of driving due to constant speed driving.

■ The start of the cruise function

Select the Cruise Mode section in the instrument panel and let go of the throttle for approximately 7 seconds. The cruise function will start.

■ End of cruise function

When you hold and release the brake while cruise mode is in effect, the cruise mode is automatically released



■ Precautions when using the cruise function



Caution

- In case of cruise function, please ride in a position where brake can be used immediately so that cruise function is canceled and braking is possible in preparation for safety situation while driving.
- This product is always operated in dual drive mode and cancel of cruise mode is possible through throttle and brake.
 ※ Cancel of cruise mood through throttle is not recommended.

6 Setting of Electronic brake

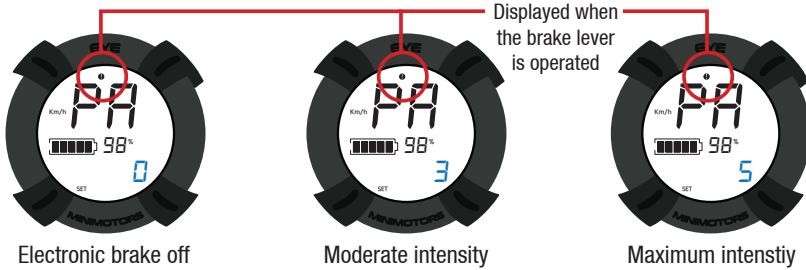

■ Precautions when using electronic brake immediately after full battery charge

The electronic brakes do not operate when the battery is fully charged, so be sure to check and operate this device. When the battery runs out, the electronic brake will operate normally.

7 ABS function setting guide

All electric motorcycles are subject to sudden braking, causing the wheels to stop spinning (Tire Lock). As a result, the slip of tire causes the driver to fall down, which can cause accidents. This product is equipped with ABS brake function to hold the tire lock, enabling more secure braking

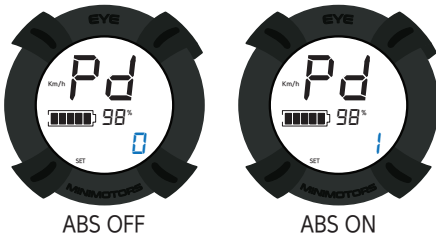

■ ABS function ON

Set the ABS function part Pd of the dashboard to 1.

■ ABS function OFF

Set the ABS function part Pd of the dashboard to 0.

* Pd – When the ABS function is ON, the PA – electronic brake can be operated at maximum, and when the ABS function is canceled, the previously set electromagnet brake operating value is applied.

* ABS brake is an abbreviation of Anti-Lock Brake System. It uses the principle that maximum static friction force is larger than kinetic friction, so that braking distance (distance from breaking to stopping) is shorter than that of normal brake. It has the advantage that the vehicle does not slip well when wheel is rotating. and it is a brake assist system that can stop more safely without wheel lock and slip

Electronic kick-board Anti-Lock Brake System Patent application nos. 10-2018-0045825



■ Precautions when using the ABS function

ABS has the advantage of being able to stop at the shortest braking distance that can be obtained from the tires and road conditions. However, due to the principle of repeatedly holding and releasing the brake several times in a second, a lot of vibration occurs in the motor and the body. Repetitive vibration caused by this may cause frequent loosening of the motor, rim, fixing part and body fixing bolt

8 Self-diagnosis through Instrument panel



Fault type	Diagnosis	Solution
②	System error	* If the error information appears, immediately stop using the product and take the scooter to the service center before use. Excessive use can result in damage to the product and safety accidents.
④	Motor error	
⑤	Accelerator error	
⑥	Controller error	
⑦⑧⑨	None	

* ① is displayed when driving at a certain speed while the cruise function is activated.

* ③ is displayed when the brake lever is operated. (When the indicator lights, the accelerator does not operate.)

1 LED function guide

When turning on the LED, press the sub battery power button on the right side of the steering to power on the handle. At this time, you can turn on the LED by pressing the top LED lighting button.



LED light system Cover precautions



Caution

Cracks in the LED cover (* solvent cracks) can be caused by direct sunlight or the solutions used for product maintenance such as polish, oil or wax. When using or servicing the product, always pay attention not to touch the LED cover with a direct sunlight, solution containing polish, or alcohol.

*Solvent cracks are minute cracks that occur when a solvent touches the surface of the resin molding.

Solvents include not only chemicals such as alcohol, but also oils, waxes, and cosmetics that are commonly used in daily life.

2 Voltmeter function guide

The batter volt meter is installed as standard to check the battery voltage in real time.

Main battery volt meter

The main battery voltage is turned on when the instrument panel is powered up.

Sub battery volt meter

The sub battery volt meter turned on with pressing the sub battery power button on the right side of the steering tube.

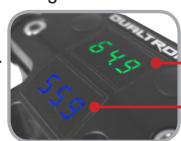

Main battery volt meter (GREEN)
Sub battery volt meter (BLUE)

3 USB charging port usage guideline

USB charging port operates on sub battery power. You can easily charge your mobile phone, Action Cam etc within the allowed output range.

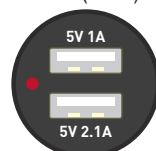

Caution

USB charging port using precaution

Connecting a high-power device that is not allowed to the USB charging port may damage the USB charging port and the product.

* Always close the USB protective cap after use to prevent moisture and foreign matter from penetrating.

1 Basic charging method

1. Open the chargingport cap and connect it to the connector of the charger and connect it to the household outlet.
2. Charging status indicator ● (Red) Charging
● (Green) Charging complete
3. Be sure to close the chargingport cap when driving or storing except when charging.
4. When connecting the connector to the charging port, metallic sparks due to voltage difference may be splashed, but this is normal.







2P charging port (Handle part 1EA, Right side of body 1EA)



3P rapid charging port (Left side of body 2EA)



2 Basic charging method : ※ Failure of the charger and abnormal conditions can cause electric shock and fire. Learn the correct usage and prevent safety accidents in advance.

<p>1. Manufacturers and sellers are not responsible for any problems arising from any disassembly, modification, or mixing with other chargers.</p> 	<p>2. The charger is forbidden to be used in places subject to high humidity, heat, flammable materials, confined spaces, or where there is no ventilation such as in a car.</p> 
<p>3. The charger is not waterproof. It is thoroughly controlled to prevent moisture from entering the charger.</p> 	<p>4. Children and pets should not be allowed to approach the charger when they come into contact with them, as they may cause an electric shock.</p> 
<p>5. If the charger lamp does not light, charger fall, strong external shock, long time charge, or cable cover damage, discontinue use immediately and contact the service center</p> 	<p>6. Unplug the charger when you are away from the home for long periods of time.</p> 

7. Use only genuine charger.
8. Do not insert conductors into the charging port.
9. Do not touch the plug for about 10 seconds after unplugging the charger. There is a risk of electric shock from instantaneous discharge.
10. Do not remove the terminal during charging. Charge the internal circuit of the charger and cause malfunction.
11. Do not operate the product during charging.
12. Charging terminals should be firmly contacted during charging and should not be used if terminals are corroded or damaged.
13. When disconnecting the charger from the product, it is safe to hold the terminal without holding the wire.
14. After charging is completed, be sure to store the charger unplugged from the product. If the charger is connected for a long time more than a few days, there is a risk of an accident due to overcharging.



***Short-circuit Caution:** Be careful not to short-circuit the battery because short-circuiting of the battery is very dangerous.

*** Overcurrent Note:** The battery of this product is designed to automatically shut off the power supply to protect the battery when the over current is over 120A (main battery) / 15A (sub battery).

*** Low Voltage Caution:** The battery of this product is designed to be automatically shut off when the voltage drops below 36.8V(main battery) / 40V(sub battery). Do not use the product in the low voltage state.





- 1. Care** Lithium batteries should be protected from direct exposure to children and pets.
- 2. Performance**
 - ① Lithium battery is affected by external temperature. In winter, when the temperature is low, the performance of the battery is temporarily deteriorated and the mileage and power output is reduced.
 - ② Lithium battery has a characteristic that discharge performance is reduced by more than 15% when charging / discharging 300 times or more. If usage time is shortened due to long usage, it should be replaced with a genuine one through the nearest point.
- 3. Charging**
 - ① Lithium battery should be used only with genuine battery and charger supplied from the manufacturer. Any problems caused by use of battery made by the manufacturer, mixed use, or using the charger are not covered by the manufacturer.
 - ② Charging the lithium battery with a non-genuine charger may cause malfunction or fire
 - ③ The lithium battery should be charged in a well-ventilated, dry place and around the charger in a place where there is no inflammable material.
 - ④ Lithium battery should be charged at 0 ~ 45 °C and discharged within -10 ~ 60 °C for main battery, charged at 0~50°C and discharged within -20~75°C for sub battery. Charging or discharging at a temperature outside this range may cause malfunction, fire or explosion.
 - ⑤ In case of moving from cold outside to warm indoor, please charge it after 1 ~ 2 hours. This is to prevent condensation from occurring inside the product due to temperature difference.
- 4. Storage**
 - ① Lithium batteries should be kept away from snow, rain and direct sunlight. Do not store or charge them in a trunk or hot room. Select a dry place and store at room temperature (10 ~ 20 °C).
 - ② When storing for more than 3 months, charge the remaining battery level to 70 ~ 80% (do not store full charge)
- 5. Trouble symptom, safety**
 - ① Lithium battery should be discontinued immediately if it is damaged or leakage of battery, sour odor, appearance deformation, etc., and contact the place of purchase to get technical support and service.
 - ② If overheat, smoke or ignition is detected in a product with lithium battery, immediately stop charging and use, move the product outdoors as soon as possible, and then use a fire extinguisher to evolve. Do not spray water or immerse the product in order to evolve, which is more dangerous.
 - ③ Lithium battery pack has very high energy density, so if you charge the battery for a long time in case of short-circuit, leakage, bad battery, etc., there is a possibility of ignition. Therefore, you should avoid charging for a long time without a person, and charging must be done while the person is aware that the risk of unexpected fire can be avoided.
- 6. Misuse** If the lithium battery is short-circuited or the polarity is changed, or if the battery is impacted, malfunction or fire may result. If you think that the battery has been impacted, you should stop charging and using it and visit the nearest point for inspection.
- 7. Water inflow** It should be controlled to prevent water inflow into the lithium battery. There is a risk of fire or electric shock if the charger is connected while moisture is present.
- 8 . Caution** Disconnect the battery from the main unit and prohibit recharging, reinstalling, or using other applications.
- 9. Disposal** Disposal When disposing of the lithium battery, the battery should be separated from the product at the point of purchase or near the point so that the charge and discharge terminals are not short-circuited. Dispose of it as industrial waste when disposing of it.



Battery disassembly prohibited

Battery disassembly, modification and repair are not covered under warranty.

1 Required checking before use

1. Check throttle and handle

- Operate the accelerator throttle lever about 2 ~ 3 times to check whether it returns to the home position.
- Be careful that excessive throttle leaning and manipulation of the throttle can cause malfunction due to internal parts damage.
- Check the fastening condition and clearance of the handle.



2. Check brake and cable

- The brake braking force is sufficient to check the operating condition. If the braking force is significantly lowered, use it immediately after inspection and action.
- Check that the brake pad is not worn, that the cable is not loose, that the cable is not damaged, or that there is no leakage in the case of hydraulic brakes
- If there is an unusual feeling or noise during operation, check for breakage, wear and deformation of the inner wire of the brake cable.
- Check that the bolts and nuts of the brake fixing parts are not loose, and that the disc is not deformed or damaged.



3. Check tire pressure and uniaxial condition

- Check the front and rear tires for wear and punctures and check the proper air pressure for the tire. When the shortage of air is shortened, the possibility of puncture increases, so check always.
- It is necessary to judge the replacement time by observing the appearance of the tire such as tire damage, uneven wear



4. Tightening check such as folding part and handle part

- Make sure that the bolts and nuts of all parts of the product are tight and free from loosening. Check the fastening condition and clearance of the folding and fixing parts of the handle (folding knob, swing arm, suspension arm, swing arm bolt, etc.).



* In this case, stop driving immediately

If you encounter any of the following situations while driving, stop driving immediately and contact your nearest branch or service center for proper measures. If you provide pictures and videos to get accurate diagnosis, professional counseling is available.



- Unusual heating of the motor
- abnormal noise is generated
- When other driving is judged to be unreasonable
- Brake braking status error
- Product smoke, ignition, sour odor
- Error messages on the instrument panel
- When the throttle is not returned to its original position
- When rain or wet with water or in a similar situation
- When it is not fully charged or when the mileage drops significantly after fully charged (Battery explosion potential because of battery cell failure and cell balance destruction)

2 Maintenance and self-maintenance

Electric products can be damaged by various factors. The life span of each part varies depending on driving habits and driving environment. Parts that exceed the service life may cause accidents. Let's manage various parts and prevent safety accidents in advance.



1. Check the replacement timing of consumable parts

- ① The components and suspension parts of the car swing arm, tires, tubes, wheels, bearings, headset bearings, discs, brake pads, cables and folding parts, various brackets and other consumable parts requiring periodic inspection and always check.

Fatigue failure parts and maintenance parts replacement cycle		
DUALTRON X		
No.	Parts name	Replacement cycle / km
1	HANDLE BODY	3 years / 20,000
2	STEERING TUBE	3 years / 20,000
3	BATTERY	2 years / 20,000
4	Other chassis components	If the exterior is damaged or deformed



2. External damage inspection by driving environment



- ① Replace parts that may be damaged by external driving environment, such as deformation of parts, cracks due to compression, and signs of exceeding fine gold or life expectancy.
- ② If the product is exposed to strong sunlight for a long time, discoloration may occur.
- ③ In case of heavy driving such as normal jumps, slight impacts such as turning, collision, etc., when driving frequently or for a long time in a poor road condition or driving for thousands of kilometers or more, fatigue breakdown phenomena Please check and replace the parts replacement schedule for each product for safety.
- ④ Fatigue breakdown and maintenance parts may differ from the example conditions depending on the driving environment and the operating conditions. Also check parts other than the replacement cycle (maintenance parts) at all times to check for any signs of abnormality.



Important notice

- While driving, metal sounds from motor vibrations, tremors from brake discs and pads, etc., may occur in the accelerating load range (torsional vibration). (About 150~30Km, depends on the product) This is a phenomenon in which vibrations occur at a certain rpm of all rotating bodies (fans, cars, ships, etc.) that are not abnormal. However continuous noise or a loud metal sound, there is a possibility of deformation such as bending of the disk. You need a regular checkup.
 - After driving, be careful as there is a risk of burns due to the heat on the motor and brake (especially the disc rotor) side.
 - Please note that the bolts of motor, rim, motor shaft and other fixing parts can be loosened by ABS function.
 - When removing and assembling the side cover for checking and repairing for the light, charging port, power switch, etc. please use standard bolt and tight carefully to avoid the sheathing of wiring. If tightening with a bolt other than the standard bolt (long bolt), the battery case(battery cell) may be fatally damaged, resulting in a fire or safety accident.
- ※ Due to the nature of the product, the folds and joints where movement occurs can be easily damaged during use. Especially, this can happen when operating with inaccurate behavior or form.
- ※ When checking the product, keep the two wheels off the ground and work on a safe work surface.

3 Maintenance by self-maintenance

1. Brake adjustment method

If the brake is used for a long time such as downhill or if the brake braking force decreases due to overheat of oil, malfunction of oil hose, loosening of the brake lever or oil leakage, etc. stop using it and please visit the service center before use.



2. Tire replacement method

1. After removing the calipers, remove the motor using 18mm spanner and disassemble the wheel and motor fastening bolts.
2. Remove the wind from the tires and press the tires off the wheel.
3. Replace the tires and complete the assembly of the tires in reverse order. Tighten the assembled tire to fit the body, then tighten the screws and bolts.



- * Caution
- After completing the tire replacement, try a simple test run with the appropriate air pressure.
 - When puncture is occurred, it is possible to use repair by using patch seal. Please use the tire while checking and checking continuously

Easy-wheel system

- Completely separable hub motor design By designing the rim and hub motor to be completely separable it is possible to replace only the rim without replacing the entire motor when the rim breaks, thus improving the maintenance and maintenance of the product. (Patent)

3. Causes and countermeasures of disc brake noise

The disc braking method uses a disc brake method with many electric kickboards because braking power is good. However, if you get a sharp hissing sound when you hold the disc brake, dust or sand particles on the ground will spill out on the surface of the disc, causing foreign substances to be on the brake pads or disc surface, or bending due to heat or external impact. At this time, clean the inner surface of the disc by turning the wheels with a clean, dry cloth, or straightening the bent discs.

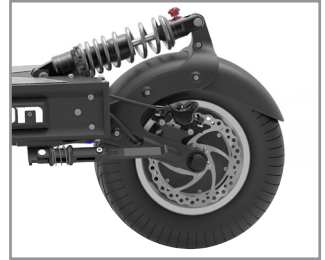

If the above measures are not taken, please visit the nearest branch and take a Caution safety check. There may be another problem.

4. Adjusting the handlebar clearance

If there is play in the handle, use the 2.5mm or 3mm hexagon wrench to adjust the adjustment bolt that appears when the handle is folded. Turn finely counterclockwise, then expand the handle to check for clearance. If there is play, repeat it slowly until there is no play.

Caution : When adjusting the clearance, if the bolt is protruded more than necessary, the handle will not be fully extended. At this time, the damage of external handle body may caused by excessive connection. If the handle body and handle bar are not normally combined because of over protruded, tighten the adjusting bolt clockwise little by little and adjust by reducing the protrusion.

5. Adjusting folding clearance

If there is a play in the folding part, tighten the folding knob completely to eliminate the play.

When no product folding is required (always unfolding)

Remove the bolts cover cap on both sides of the front folding higer bolts, and tighten by fixing bolt. It will always be unfolded.

When folding, work in reverse order to fold.



■ Height adjustent (by weight)

You can adjust the height by turning the ring.



Suspension adjustment ring

■ Suspension Strength Adjustment

Turn the hydraulic control lever to adjust the suspension strength It is. (Adjustable according to weight or taste)



Hydraulic control lever

When adjusting the suspension ring, lift the wheel off the ground before adjusting it.

Important checklist

Guidance

* To prevent safety accidents, the following checks should be made before and during the use of the product. If the abnormal symptom are monitored or detected, stop using immediately and undergo a self-inspection or inspection by visiting your nearest Minimotors branch. After the abnormal symptoms have been resolved, the product can be used safely.

■ Throttle

- Check the acceleration throttle lever for proper operation before riding.
- When pulling or releasing the throttle lever, if you operate it with your fingers, or if you apply excessive force by pulling it hard enough to the end, it will cause excessive force on the moving parts and cause damage or breakdown, etc.
- Although it is safely designed to automatically cut off the motor power when the brake is operated,
- if a problem such as
- the acceleration throttle lever is not returned to its original position while driving or departure occurs, brake it immediately to stop, and always turn on the power while holding the brake. After turning off, please check and use safely.
- Check or replace if you notice any abnormality (such as a large play) or if the throttle is subjected to a large impact.
- It is recommended to check the loss or looseness of the throttle and casing fixing bolts before use.
- Grease the operating part of the throttle lever to maintain smooth operation.

■ Folding body

- Due to the impact of collisions that are not continuous extreme driving or normal driving, falling, heavy equipment on the steering wheel etc., the stress can accumulate on related parts such as hinges, fixing bolts and folding knobs. As these parts are not permanent which can be weakened or broken, the parts must be replaced after certain period.

■ Folding knob

- Check the tightness of folding knob, whether handlebar in not moving.
- In the event of play, be sure to check and fix before using.

Precautions

■ Precautions before using

In order to use the product safely, please read and understand the instruction manual including this manual.

- (1) When using the product, be sure to use a full face helmet and upper body protector to protect your head. Wear joint guards such as gloves, knee pads, and elbow pads.
- (2) Please note that if the clothes, bags, shoelaces, fingers, hair, etc may be placed on the rotating part (motor, tire, wheel, disc) it may cause a safety accident.
- (5) Shoes such as slippers and high heels that prevent the safe operation are prohibited due to accidents.
- (4) No alcohol, no licence, no more than one person, no cargo loading.
- (5) Stunts that cause safety accidents or product malfunctions are prohibited.
- (6) As it is not waterproof, water may get into the product (eg water cleaning), or condensation may occur (The movement of the temperature difference in winter greatly changes), drive on wet roads in the rain or snow is forbidden.
- (7) The handle must be held firmly with both hands and should always be used for unforeseen circumstances. Hold the handle so that you can hold the brakes immediately.
- (8) The built-in DC converter is not allowed to use additional connections for LED tuning or other purposes.

■ Lithium Battery Precautions

- (1) Charge only with a genuine Mini Motors KC-certified charger. (2) Do not disassemble, immerse or modify the product.
- (3) Charge Main battery at 0 ~ 45 °C, discharge within -10 ~ 60 °C, charge sub battery at 0 ~ 50 °C, discharge within -20 ~ 75
- (4) In case of long term storage, charge the battery with 70 ~ 80%.
- (5) If the battery unit detects overheating, smoke, or ignition, immediately stop using and charging the product. You have to evolve using a fire extinguisher.

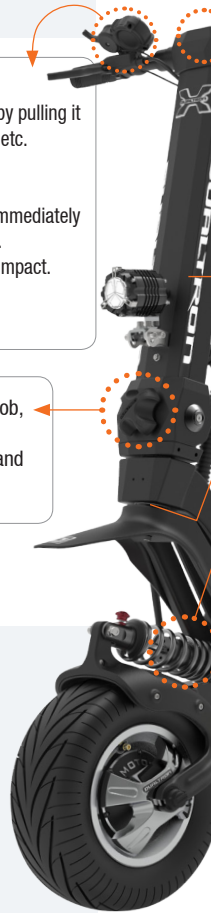



■ **Grip**

- Use it after taking measures against play, such as turning or removing the handlebar.

■ **Brake cable**

- Check for damage to wires at both ends of the lever and disc brake, external bending, oil leakage, and so on.
- Check or replace the brake when it is not working properly.

■ **Brake lever**

- After operation, check or replace the unit after a large impact such as a large play or fall.
- If the motor disconnection wiring is damaged and the motor power cutoff is defective, be sure to use it after taking measures.
- Always check that the hydraulic brake braking force is sufficient before driving and use after action.

■ **Handle body**

- Tighten and secure the fixing bolts, Check for cracks.

■ **Handle Post (Steering Tube)**

- Check the bolt nut tightness on each fixing part of the handle configuration.
- Do not install excessive attachments (baskets, bags, etc.) on the column and handle. Excessive load on the folding part can cause a safety accident due to difficulty of steering and excessive load on the folding part.

■ **Headset bearing**

- Keep operation smooth.
- Use after action in play.

■ **Front, back suspension**

- Loosen the bolts and nuts of the relevant part to fix the suspension after a certain time of use Check the fixed state such as the rim, and the suspension restoring force is reduced or bent When loads, cracks and deformations occur, they must be replaced before use.

■ **Side stand**

- If you ride on the product or drive with the side stand upright, do not attach to the side stand as this may cause damage to the product or safety accidents. It is forbidden to apply reasonable force.

■ **Suspension arm fixing bolt**

- When the suspension arm fixing bolt which connect the suspension arm and swing arm has a play, this may cause interference and should be checked at all times.

Regular inspection

■ **Main check**

- (1) Tightening condition of fixing bolts and nuts such as tires, wheels, motors, discs, brakes, handles, chassis, wheels, etc. Please use after checking the loss.
- (2) In case of tire damage, wear or abnormal wear, replace and use immediately.
- (3) Always check the tire pressure before riding and inflate it to the value indicated on the side of the tire.
- (4) Check the operating condition of the brake, check the pad consumption, and the oil leakage condition.
- (5) If a disc is deformed or stamped or if calibration is not possible, replace it before use.

* Use it after checking the fixing bolt, tightening condition and loss of all parts of the product except the parts not specified.

* **Throttling Use to Turn off the Cruise function:** You cannot cancel the cruise using the throttle. You can only release the brake.

* **Precautions for using Cruise function:** When the cruise function is activated, make sure that the cruise function is released and braking is possible for safety while driving. Drive the brakes in a ready position.

* **Precautions for using the ABS function:** Due to the nature of the ABS function of repeatedly holding and releasing the brake several times for one second, frequency of loosening of the fixing bolts such as motor, rim, and motor shaft may increase. Checking always is required.

Product Name	Electronic kick-board	Model name	DUALTRON X H35E
Motor	MAX 6720W BLDC DUAL HUB MOTOR		
Battery type	Li-Ion battery pack	SAMSUNG SDI	
Battery capacity (main battery)	60V 49Ah	2940Wh	
Battery capacity (sub battery)	60V 3Ah	180Wh	
Charging time (1.75A)	28hr+(main battery) / 1.7hr+(sub battery)		With slower charger for 60V (2P) (Minimotor's genuine KC Certified Charger)
Charging time (6.5A)	7.5hr+		With rapid charger for 60V (3P) (Minimotor's genuine KC Certified Charger)
Charging time (8.25A)	5.9hr+		With rapid charger for 60V (6.5A) + slower charger for 60V (1.75A)
Max mileage	150km+		based on 75kg riding, 25km / h flat continuous driving
Max Speed	25km/h		
Folding	Turn & Push Release		Patent application method
Gradeability	About 70% or more (about 35 degrees from the back angle)		The weight of the occupants, road conditions, battery conditions, Standing power may vary depending on temperature
Max load	120kg		
Product weight	about 64.5kg		
Unfolding size	1305 x 632 x 1240mm		length(L)x width(W)x height(H)
Folding size	1305 x 350 x 780mm		length(L)x width(W)x height(H)
Dashboard	EYE Throttle Basic Application (Remaining capacity, voltage, trip, ODO, driving time, driving speed display and mode change function)		Cruise function / Electronic brake function / Auto power saving function / ABS function
LED lamp function	LED Front Lamp + Steering Tube LED Bar Luminous System + Deck side LED lamp, bottom mood lamp standard & Tail light, brake light standard		Built-in DC to DC converter (Main-12V 7A output available) (Sub-12V 3A output available)
Brake	Hydraulic brake + 160mm disc		for front and back both
Suspension	19-speed hydraulic control for bike tuning		
Tire	13 inch ultra wide tubeless tire (Maximum air pressure is indicated on the side of the tire)		Hub motor design with fully detachable structure (Patent)
Product material	Frame and Steering Handlebar: Aviation Aluminum Special Alloy Shafts: SCM, Covers: Polypropylene		

* The specification can be changed by manufacturer without notice to improve the quality and safety for users.

* The distance can be affected by loaded weight, wind direct (wind speed), road condition, slope and tire condition.

- Please keep product box for A / S.
- Most of Mini Motors' products are classified as Extreme Leisure Equipment. It is an occasional maintenance check necessary product.
- Mini-motors products are passenger products such as automobiles or motorcycles, and after the products are assembled or used, you will not be able to exchange, return or refund the product. (However, the problem with the product will be 100% resolved by Minimotors)
- In case of damage during delivery, request must be made on the day of receipt. This is not responsible by store. However, on holiday or absent, please leave a message on our website. We will handle it

I A / S and Regulation I

- Warranty for undercarriage (frame) is 1 year, the core components (motor, lithium battery, controller, throttle, charger, etc.) is 6 months from date of purchase. (Could be depend on the products)
- General parts, excluding core parts, are warranted for 3 months from the date of purchase in accordance with the Leisure Sporting Goods Rewards Practice. Consumables (tires, tubes, discs, pads, cables and other consumables that require periodic inspection and consumable parts) are subject to paid repairs.
- Even during the warranty period, any damage caused by inundation, damage, arbitrary disassembly or modification by the customer, in the case of intestines, paid repairs apply.
- If you visit a branch other than the one where you purchased the product for service, you will not be charged for the parts. However, labor may be charged even during the free service period. Therefore, we ask that you purchase the product mainly from the point of service.
- Lithium batteries that have been damaged during use or have serious damage such as leaks or odors should be replaced.
If the damaged lithium battery is used without repair, serious accidents such as a fire may occur in the future. If the problem occurs after rejecting the replacement advice from the dealer and continuing to use it, the manufacturer or sales person is not responsible for it.
- Never charge a flooded lithium battery, as it is very dangerous to charge it.

I Exchange and Return Information I

- You must request for an exchange or return within 7 days of receiving the box unopened. The exchange of goods is limited to one time, and the returned goods will be processed again without notice. Please be sure to handle it after talking with the person in charge.
- In case of exchange or refund due to your simple change of mind, you have to pay the full round-trip courier fee. You must send it to your dealer.
- Our minimotors take 2 to 4 days from the date of order and delivery may be delayed due to congestion.

I Customer consultation I

- Consultation available : 1666-8596
- Consultation time : 오전 10시 ~ 오후 6시 | Consultation is not available on Saturdays, Sundays and public holidays.
- Lunch break : 12시~ 오후 1시

품질 보증서

Minimotors Co. LTD.

www.minimotors.co.kr

This product is inspected at the manufacturing factory and sales branch before sale and finally shipped. Please be aware that some initial defects and defects may occur from time to time due to the nature of the product before purchase. All repairs for initial defect or defect found after using the product are provided within the free warranty period.

Product name	DUALTRON X H35E (Adult Electric Kickboard)		
Manufacturer	Address	88-12, Chukhyeonsandan-ro, Tanhyeon-myeon, Paju-si, Gyeonggi-do, Republic of Korea	
	Company name	Minimotors Co. LTD.	
Place of sale	Address	88-12, Chukhyeonsandan-ro, Tanhyeon-myeon, Paju-si, Gyeonggi-do, Republic of Korea	branch of sale
	Company name	Minimotors Co. LTD.	Date of sale
Consumer center	1666-8596 (Monday~Friday AM10:00 ~ PM06:00)		S/N
			Contact

Paid	Free
<p>1. Out of warranty period</p> <p>2. Within warranty</p> <ul style="list-style-type: none"> - For consumables (tire, tube, bearings, brake pads, oils, various cables, etc. parts consumed or requiring maintenance) - Breakdown caused by inadvertent handling of consumers. - Breakdown caused by transportation and movement after handing over to consumers. - When the contents of the product are arbitrarily changed, modified or damaged at any repair shop. - Failure due to natural disasters such as fire, flooding, flooding - Without product warranty. 	<p>1. Within warranty</p> <ul style="list-style-type: none"> - 1year : Chassis - 6month : Key components (Motor, battery, controller, throttle, charger only) - 3month : General parts - Check the sales date on the warranty card to guarantee - Guaranteed based on production date without warranty <p>2. Lithium Battery Pack Warranty (Sale date-within six months)</p> <ul style="list-style-type: none"> - Within 300km : Free - Less than 300km ~ 3000km : Paid (10,000 won per 100km) - Over 3000 km, Breakdown due to flooding : paid

* If defects occur due to defects in product manufacturing during normal use within the warranty period, We will repair it.

* Regulations on Delivery Costs for A / S: For the repair, you have to visit the place where you bought the product. If you deliver the product for the repair, you have to pay for round trip fee for deliver.

	지점명	연락처
서울지역	강남지점	010-3241-2466 / 02-572-9990
	강동지점	010-3261-2466 / 02-426-4648
	관악지점	010-9231-4210 / 0507-1317-4210
	구로지점	010-8640-5141 / 02-599-5141
	노원지점	010-3939-1499 / 02-972-2422
	마포지점	010-6290-8512 / 02-324-3998
경기지역	김포지점	010-3390-0664
	남양주지점	010-5383-7587 / 031-557-7587
	동탄지점	010-3469-2422 / 031-375-2423
	성남지점	010-6419-9461 / 031-723-8297
	수원지점	010-6419-9461 / 031-211-2422
	안산지점	010-7422-2466 / 031-402-2466
	안양지점	010-9001-1593 / 031-429-1591
	의정부지점	010-3040-4600 / 031-852-0089
	이천지점	010-3363-7778 / 031-631-0015
	인천지점	010-4227-4338 / 032-518-5735
	인천송도점	010-8760-0050 / 032-833-2050
	일산지점	010-9357-8338 / 031-975-5333
파주지점	010-9341-3032 / 031-943-7337	
충청지역	대전지점	010-3429-2028
	세종지점	010-8290-1200
	천안지점	010-4111-6127 / 041-565-2422
	청주지점	010-9898-5114
경상지역	구미지점	010-8597-8830 / 054-456-1900
	대구지점	010-6513-4272 / 053-270-8737
	동부산지점	010-5877-8151 / 051-704-8151
	서부산지점	010-8499-0072 / 051-323-2222
	울산지점	052-227-2203
	진주지점	055-761-1588
	창원지점	010-2087-4844 / 070-4146-4549
전라지역	광주지점	010-2914-6317 / 062-383-8444
	순천지점	010-9447-1060 / 061-723-1060
강원지역	원주지점	010-9174-5714
제주지역	제주지점	010-3639-4548 / 064-744-0289

* 미니모터스의 전국 지점은 판매와 A/S를 동시에 지원합니다.
 지점 방문 시 반드시 유선 연락 또는 본사 홈페이지
 (www.minimotors.co.kr/ 전국 지점 안내)에서 위치를 확인하신 후 방문하시기 바랍니다.

DUALTRON X Electric Scooter User Manual



· 모델명 : DUALTRON X H35E · 판매원 : (주)미니모터스
· 전자파 인증번호 : R-R-ELT-DUALTRONX · A/S 문의 : 1666-8596
· 차대부품 (중국) / 배터리팩 (한국) · 조립공장 : (주)미니모터스 (한국)
· 주소 : 경기도 파주시 탄현면 축현산단로 88-12
· 사용연령 : 18세 이상 · 최대하중 : 120kg

고객
센터 **1666-8596**

kakaotalk Yellow ID : @미니모터스
상담가능 시간 : AM 10:00~PM 6:00
(토, 일 공휴일은 제외/PM 12:00~1:00 점심시간)
www.minimotors.co.kr

